



AIR CONDITIONING



REFRIGERATION



HEATING



# mini blanc

## CONDENSATE REMOVAL PUMP

The 'ultra quick fit' Mini Blanc is designed to be fitted beneath high wall indoor units and offers easy access for future maintenance.



12L/h max. flow



10m max. rec. head (flow rate 4L/h)



21dB(A)

### KEY FEATURES

- Extra quick to fit
- Compact & discreet
- Clear removable reservoir
- Ultra quiet operation

### SUITABILITY

- Up to 16kW / 54,000Btu/h
- High wall mini split systems
- ✓ **Perfect for...** Domestic use – where easy maintenance is key

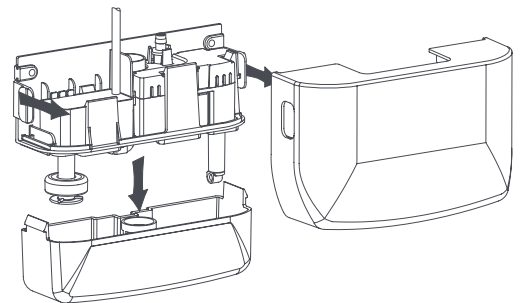
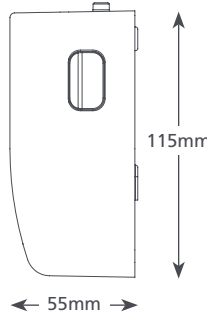
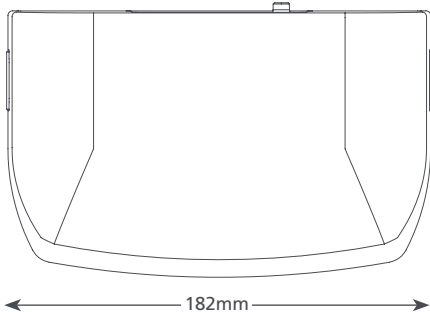

### MINI BLANC SPECIFICATIONS

Max. flow	12L/h @ 0 head
Max. rec. head	10m
Max. suction lift	n/a
Sound level@1m	21dB(A)
Power supply	230V AC 50-60Hz 0.1A*
Rated	Non continuous
Class	II appliance <input type="checkbox"/>
Max. unit output	16kW / 54,000Btu/h
Max. water temp	40°C / 104°F
Inlet/outlet	20mm in, 6mm out
IP Protection	IPX1
Safety switch	3.0A Normally closed
Thermal protection	✓
Fully potted	✓
Self priming	n/a

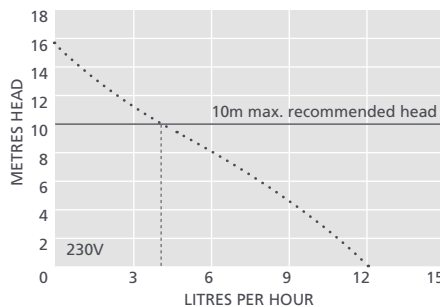

### SUGGESTED XTRA ACCESSORIES

Description	Part No.
1 Amp Fuse	FP2620
Tube To Soil Stack Adaptor	FP2038
Mini Blanc Ivory Cover	FP1037

*Xtra* For more installation accessories take a look at our Aspen Xtra range

### MINI BLANC OPTIONS

Mini Blanc FP1080/2

\*Other voltages available

### IN THE BOX

Mini Blanc pump (including hard wired 1.5m power cable) • Anti siphon device • Drain connector kit • Fixing kit • Install manual

Download manual at [aspenpumps.com](http://aspenpumps.com)

View install video at [aspenpumps.com](http://aspenpumps.com)

Information correct at time of going to press.



[aspenpumps.com](http://aspenpumps.com)

+44 (0)1323 848842

[sales@aspenpumps.com](mailto:sales@aspenpumps.com)

Making life easier for the installer